

# Intelligent Photoelectric Smoke Detector

## SIGA-PS



### Overview

The Signature Series Model SIGA-PS Intelligent Photoelectric Smoke Detector gathers analog information from its smoke sensing element and converts it into digital signals. The detector's on-board microprocessor measures and analyzes these signals. It compares the information to historical readings and time patterns to make an alarm decision. Digital filters remove signal patterns that are not typical of fires. Unwanted alarms are virtually eliminated.

The microprocessor in each detector provides four additional benefits - Self-diagnostics and History Log, Automatic Device Mapping, Stand-alone Operation and Fast, Stable Communication.

**Self-diagnostics and History Log** - Each Signature Series detector constantly runs self-checks to provide important maintenance information. The results of the self-check are automatically updated and permanently stored in the detector's non-volatile memory

**Automatic Device Mapping** - The loop controller learns where each device's serial number address is installed relative to other devices on the circuit. The mapping feature provides supervision of each device's installed location to prevent a detector from being reinstalled (after cleaning etc.) in a different location from where it was originally.

**Stand-alone Operation** - A decentralized alarm decision by the detector is guaranteed. On-board intelligence permits the detector to operate in stand-alone mode. If loop controller CPU communications fail for more than four seconds, all devices on that circuit go into stand-alone mode. The circuit acts like a conventional alarm

receiving circuit.

**Fast Stable Communication** - On-board intelligence means less information needs to be sent between the detector and the loop controller. Other than regular supervisory polling response, the detector only needs to communicate with the loop controller when it has something new to report.

### Standard Features

- Integral microprocessor
- Non-volatile memory
- Automatic mapping device
- Electronic addressing
- Environmental compensation
- Intelligent detector
- Wide 0.67% to 3.77%/ft. sensitivity range
- Twenty pre-alarm sensitivity values, set in 5% increments
- Identification of dirty or defective detectors
- Automatic day/night sensitivity adjustment
- Twin RED/GREEN status LEDs
- Standard, relay, fault isolator, and audible mounting bases
- Designed and manufactured to ISO 9001 standards

## Installation

Signature Series detectors mount to North American 1-gang boxes, 3-1/2 inch or 4 inch octagon boxes, and to 4 inch square electrical boxes 1-1/2 inches (38 mm) deep. They mount to European BESA and 1-gang boxes with 60.3 mm fixing centers.

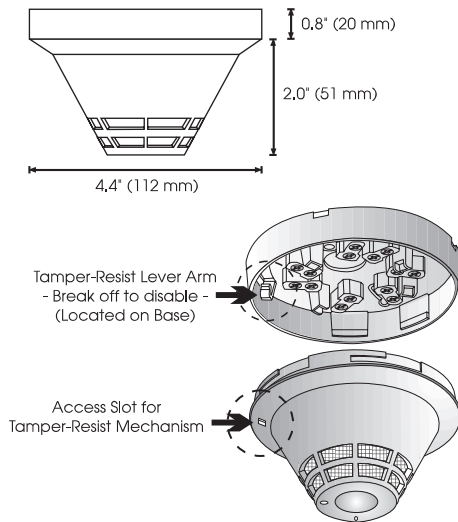

## Testing & Maintenance

Each detector automatically identifies when it is dirty or defective and causes a "dirty detector" message. The detector's sensitivity measurement can also be transmitted to the loop controller. A sensitivity report can be printed to satisfy NFPA sensitivity measurements which must be conducted at the end of the first year and every two years thereafter.

The user-friendly maintenance program shows the current state of each detector and other pertinent messages. Single detectors may be turned off temporarily from the control panel. Availability of maintenance features is dependent on the fire alarm system used. Scheduled maintenance (Regular or Selected) for proper detector operation should be planned to meet the requirements of the Authority Having Jurisdiction (AHJ). Refer to current NFPA 72 and ULC CAN/ULC 536 standards.

## Compatibility

The SIGA-PS detectors are compatible only with the Signature Loop Controller.

## Warnings & Cautions

This detector will not operate without electrical power. As fires frequently cause power interruption, we suggest you discuss further safeguards with your fire protection specialist.

This detector will NOT sense fires that start in areas where smoke cannot reach the detector. Smoke from fires in walls, roofs, or on the opposite side of closed doors may not reach the detector to alarm it.

## Accessories

All detector mounting bases have wiring terminals that are accessible from the "room-side" after mounting the base to the electrical box. The bases mount to North American 1-gang boxes and to 3 1/2 inch or 4 inch octagon boxes, 1 1/2 inches (38 mm) deep. They also mount to European BESA and 1-gang boxes with 60.3 mm fixing centers. The SIGA-SB4, SIGA-RB4, and SIGA-IB4 mount to North American 4 inch sq. electrical boxes in addition to the above boxes. They include the SIGA-TS4 Trim Skirt which is used to cover the "mounting ears" on the base. The SIGA-AB4G mounts to a 4" square box only.

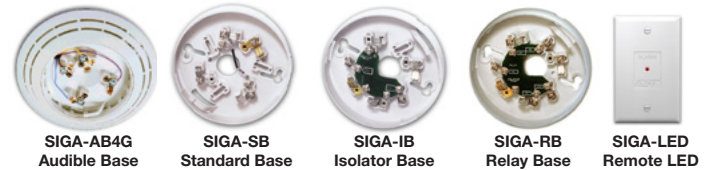

**Standard Base SIGA-SB, SIGA-SB4** - This is the basic mounting base for Edwards Signature Series detectors. The SIGA-LED Remote LED is supported by the Standard Base.

**Relay Base SIGA-RB, SIGA-RB4** - This base includes a relay. Normally open or closed operation is selected during installation. The dry contact is rated for 1 amp (pilot duty) @ 30 Vdc. The relay's position is supervised to avoid accidentally jarring it out of position. The SIGA-RB can be operated as a control relay if programmed to do so at the control panel (EST3 V.2 only). The relay base does not support the SIGA-LED Remote LED.

**Audible Base SIGA-AB4G** - This base is designed for use where localized or group alarm signaling is required. When the detector senses an alarm condition, the audible base emits a local alarm signal. The optional SIGA-CRR Polarity Reversal Relay can be used for sounding to other audible bases on the same 24 Vdc circuit.

Relay and Audible Bases operate as follows:

- at system power-up or reset, the relay is de-energized
- when a detector is installed in the base with the power on, the relay energizes for four seconds, then de-energizes
- when a detector is removed from a base with the power on, the relay is de-energized
- when the detector enters the alarm state, the relay is energized.

**Isolator Base SIGA-IB, SIGA-IB4** - This base includes a built-in line fault isolator for use on Class A circuits. A detector must be installed for it to operate. The isolator base does not support the SIGA-LED Remote LED.

The isolator operates as follows:

- a short on the line causes all isolators to open within 23 msec
- at 10 msec intervals, beginning on one side of the Class A circuit nearest the loop controller, the isolators close to provide the next isolator down the line with power
- when the isolator next to the short closes, reopens within 10 msec.

The process repeats beginning on the other side of the loop controller.

**Remote LED SIGA-LED** - The remote LED connects to the SIGA-SB or SIGA-SB4 Standard Base only. It features a North American size 1-gang plastic faceplate with a white finish and red alarm LED.

**SIGA-TS4 Trim Skirt** - Supplied with 4 inch bases, it can also be ordered separately to use with the other bases to help hide surface imperfections not covered by the smaller bases.

# Application

Although photoelectric detectors have a wide range of fire sensing capabilities they are best suited for detecting slow, smoldering fires. The table below shows six standard test fires used to rate the sensitivity of smoke and heat detectors. The table indicates that no single sensing element is suited for all test fires.

Edwards recommends that this detector be installed according to latest recognized edition of national and local fire alarm codes.

Test Fire	SIGA-IS Ion	SIGA-PS Photo	SIGA-HRS and SIGA-HFS Rate-of-Rise/ Fixed Temp.	SIGA-PHS Photo Heat 3D	SIGA-IPHS Ion/Photo/Heat 4D
Open Wood	optimum	unsuitable	optimum	very suitable	optimum
Wood Pyrolysis	suitable	optimum	unsuitable	optimum	optimum
Smouldering Cotton	very suitable	optimum	unsuitable	optimum	optimum
Poly Urethane Foam	very suitable	very suitable	suitable	very suitable	optimum
n-Heptane	optimum	very suitable	very suitable	optimum	optimum
Liquid Fire without Smoke	unsuitable	unsuitable	optimum	very suitable	very suitable

# Typical Wiring

The detector mounting bases accept #18 AWG (0.75mm<sup>2</sup>), #16 (1.0mm<sup>2</sup>), #14 AWG (1.5mm<sup>2</sup>), and #12 AWG (2.5mm<sup>2</sup>) wire sizes.

Note: Sizes #16 AWG (1.0mm<sup>2</sup>) and #18 AWG (0.75mm<sup>2</sup>) are preferred for ease of installation. See Signature Loop Controller catalog sheet for detailed wiring requirement specifications.

## Standard Detector Base, SIGA-SB, SIGA-SB4

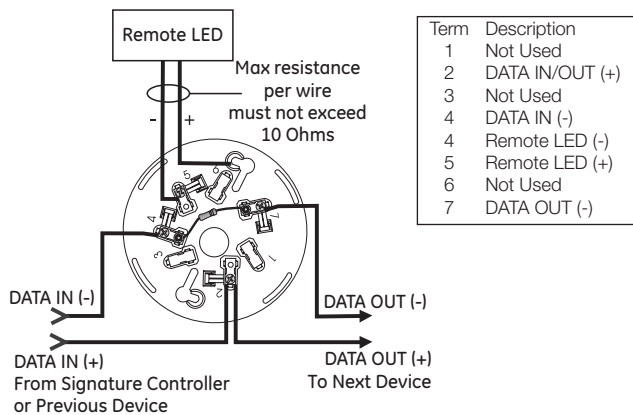

## Relay Detector Base, SIGA-RB, SIGA-RB4

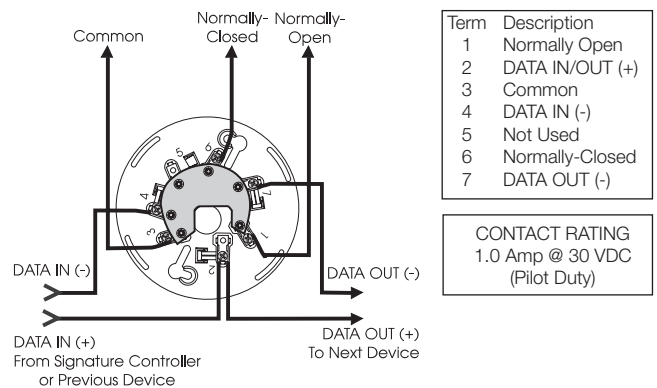

## Isolator Detector Base, SIGA-IB, SIGA-IB4

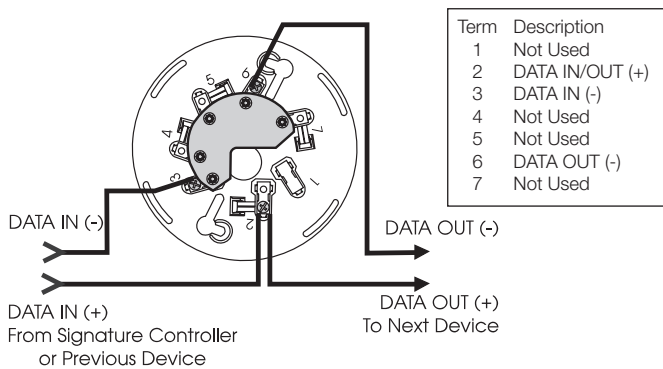

## Audible Detector Base, SIGA-AB4G

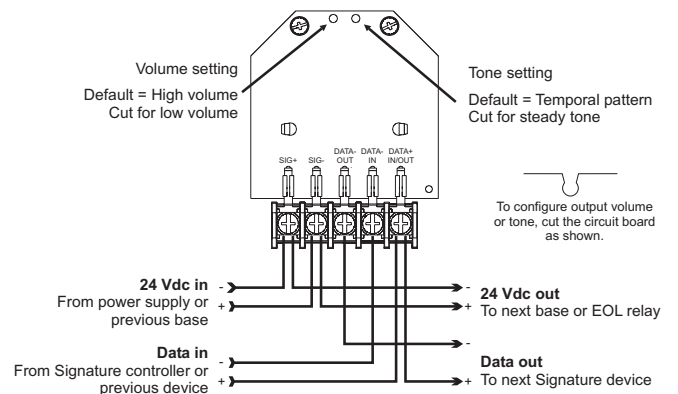



**Contact us...**

Email: [edwards.fire@fs.utc.com](mailto:edwards.fire@fs.utc.com)  
 Web: [www.est-fire.com](http://www.est-fire.com)

EST is an **EDWARDS** brand.  
 1016 Corporate Park Drive  
 Mebane, NC 27302

In Canada, contact Chubb Edwards...  
 Email: [inquiries@chubbedwards.com](mailto:inquiries@chubbedwards.com)  
 Web: [www.chubbedwards.com](http://www.chubbedwards.com)

© 2014 UTC Fire & Security Americas Corporation, Inc. All rights reserved. Specifications subject to change without notice. Edwards is part of UTC Climate, Controls & Security, a unit of United Technologies Corporation.

## Specifications

Sensing Element	Photoelectric - Light Scattering Principle
Storage & Operating Environment	Air Velocity Range: 0 to 5,000 ft/min (0 to 25.39 m/s); Humidity: 0 to 93% RH, Non-Condensing Operating Temp: 32°F to 120°F (0°C to 49°C); Storage Temp: -4°F to 140°F (-20°C to 60°C)
Sensitivity Range	ULI/ULC - 0.67% to 3.77% obscuration/foot
User Selected Alarm Sensitivity Settings	Most Sensitive: 1.0%/ft.; More Sensitive: 2.0%/ft.; Normal: 2.5%/ft.; Less Sensitive: 3.0%/ft.; Least Sensitive: 3.5%/ft.
Pre-alarm Sensitivity	5% increments, allowing up to 20 pre-alarm settings
Operating Voltage	15.2 to 19.95 Vdc (19 Vdc nominal)
Operating Current	Quiescent: 45µA @ 19 V; Alarm: 45µA @ 19 V Emergency Stand-alone Alarm Mode: 18mA Pulse Current: 100 µA (100 msec); During Communication: 9 mA max.
Construction & Finish	High Impact Engineering Polymer - White
Compatible Mounting Bases	SIGA-SB Standard Base, SIGA-RB Relay Base, SIGA-IB Isolator Base, SIGA-AB4, SIGA-AB4G Audible Bases
LED Operation	On-board Green LED - Flashes when polled; On-board Red LED - Flashes when in alarm Both LEDs - Glow steady when in alarm (stand-alone) Compatible Remote Red LED (model SIGA-LED) Flashes when in alarm
Compatibility	Use With: SIGNATURE Loop Controller
Address Requirements	Uses one Device Address
Agency Listings	UL, ULC, MEA, CSFM, FM
UL Listed Spacing	30 ft

## Ordering Information

Catalog Number	Description	Ship Wt. lbs (kg)
SIGA-PS	Intelligent Photoelectric Detector - UL/ULC Listed	0.5 (.23)
<b>Accessories</b>		
SIGA-SB	Detector Mounting Base - Standard	
SIGA-SB4	4-inch Detector Mounting Base c/w SIGA-TS4 Trim Skirt	
SIGA-RB	Detector Mounting Base w/Relay	
SIGA-RB4	4-inch Detector Mounting Base w/Relay, c/w SIGA-TS4 Trim Skirt	0.2 (.09)
SIGA-IB	Detector Mounting Base w/Fault Isolator	
SIGA-IB4	4-inch Detector Mounting Base w/ Fault Isolator, c/w SIGA-TS4 Trim Skirt	
SIGA-LED	Remote Alarm LED	
SIGA-AB4G	Audible (Sounder) Base	.3 (0.15)
SIGA-TS4	Trim Skirt (supplied with 4-inch bases)	.1 (.04)